

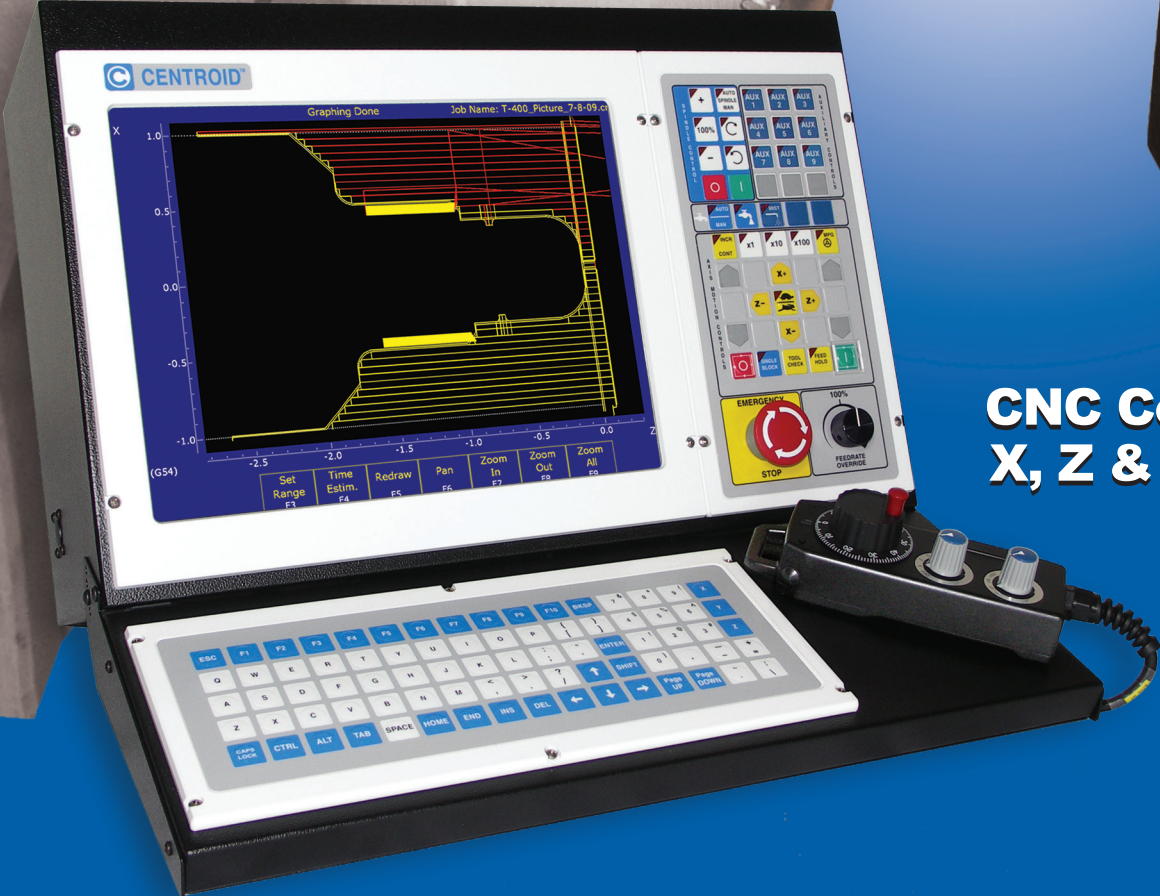

CENTROID™

T-400 CNC Control
For Lathes

Do More With A
CENTROID!



**CNC Control
X, Z & C Axis**

MADE IN USA



So Easy, You'll Turn Parts The First Day!

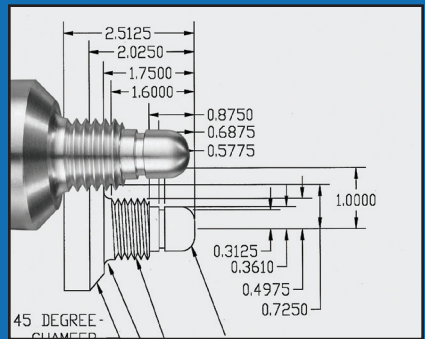

**From print to part...
in minutes!**



**Quick, at-the-machine
part programming
with Intercon**

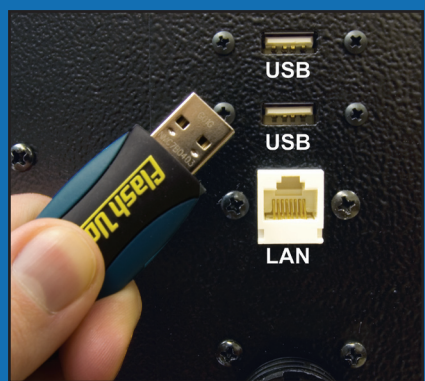

**Easy file transfer with
USB & Ethernet LAN**

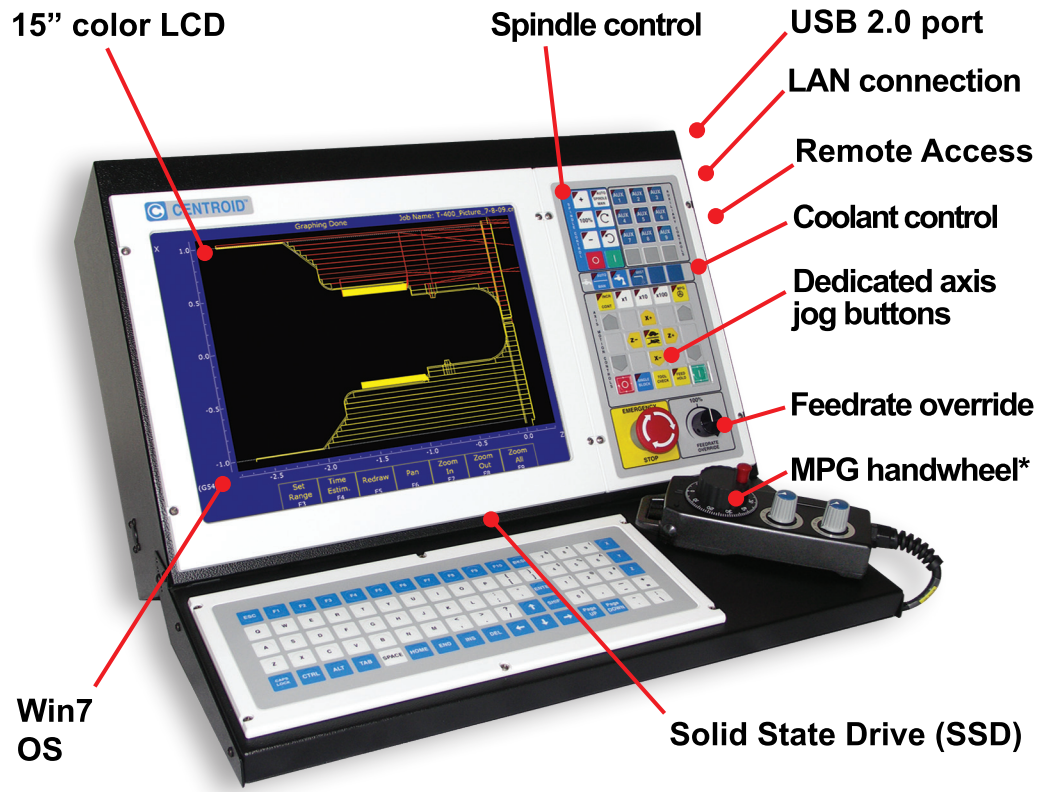

Do more with a CENTROID!

- Cut parts the first day with intuitive, straightforward operation
- Increase production with faster setups and easier programming
- Expand your machining applications and compete on higher paying jobs without higher cost
- Easily transfer programs from any computer system by using USB or Ethernet LAN

Advanced features include:

- Multi axis simultaneous motion control with spindle speed control
- High-speed accel/decel look ahead
- Digital servo amplifiers and motors
- Large, built-in solid state hard drive
- Tool wear offset adjustment
- Use new or reuse existing servos
- AC or DC servo motors
- 17 in-lb to 700 in-lb motors available
- Laser Ballscrew compensation
- Easy-to-use part and tool setup menus
- Large, easy-to-read color LCD display
- Tool path graphics, with runtime display
- Accepts standard G-Codes from CAD/CAM

Intercon Conversational Programming

- Quickly create part programs right at the control
- Easy "fill in the blank" menus
- Graphical help menu with math assistance for missing dimensions
- Software automatically generates the G-code
- Check your work instantly with tool path graphics
- No knowledge of G-codes necessary
- Drill, bore and tap*

Full Graphical Preview

- Preview and step through your part program before cutting
- Easily identify and correct over travel events
- Accurately estimate actual job run time
- Stop and start the preview at any point
- Eliminate wasted time and material by confidently producing perfect parts on the first program run

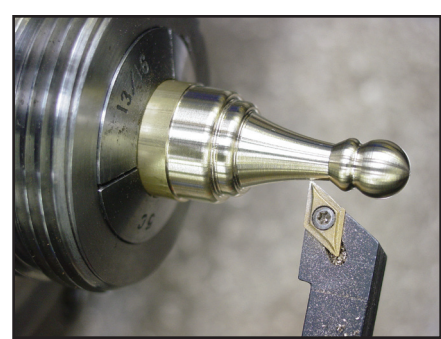
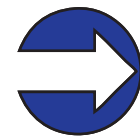
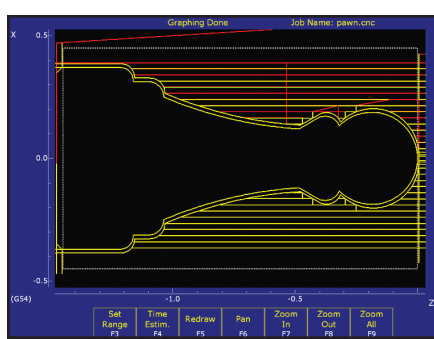

Features you need in a CNC Lathe

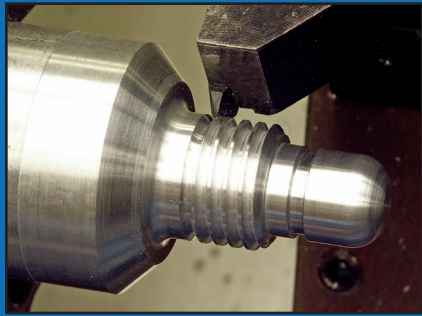

Threading Cycles

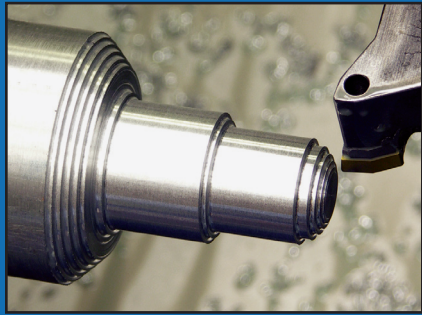

Automatic Profiling

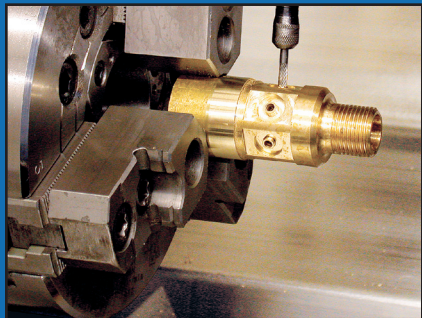

C Axis Positioning

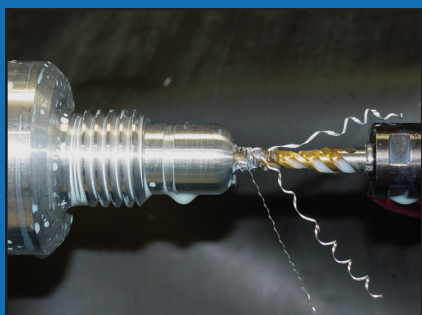

Drill/Bore and Tap

Fast, menu-driven part & tool setups

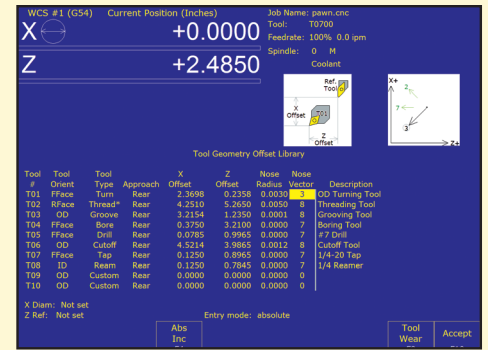

Simple Setup

- Easy-to-use graphical menus guide you through part and tool setups.
- Tool library, offsets, and zero-positions are stored in the T400's memory, even after the machine is turned off and restarted — never reset a tool or part position again!
- Stop and restart jobs at any point — make adjustments to the tool offset or part program and resume where you left off with the push of a button.

Threading and Grooving Cycles

- Canned threading cycles include Inside, Outside, Compound, and Tapered thread cycles.
- Threading cycles can be used by simply selecting the type of thread and entering pitch, diameter, and length.
- Grooving canned cycles can make Straight, Chamfered, or Radiused Grooves — on the inside, outside, front, or back of the part.

Automatic Profiling

- Automatic material removal saves time by generating all the commands to remove excess material from stock.
- Profiles are defined by simple lines and arcs, and material around the profile is automatically “roughed off”.

C Axis Positioning*

- Used for contour milling and spindle positioning for drilling and tapping.
- Produce special profiles such as square sides, pockets, cams, and even lettering.
- Provides accurate positioning around the circumference, on the face, or inside the part.

Constant Surface Speed Control

- Spindle automatically adjusts RPM to provide the correct surface speed that you have specified over the entire part.
- Ensures consistent surface finish, superior turning, and longer tool life.

Tapering

- Add any taper to your part, at any angle, by specifying a start and end point, or use the angle and length of the taper.
- CENTROID's conversational programming will automatically calculate any unknown values.

Drill/Bore and Tapping

- Canned drill/bore cycles include: Peck drill/bore (chip breaking), Deep Hole drill/bore (chip removal), and Drill/Bore.
- Use a tap to make threads with the canned Floating-tap or Rigid-tap cycle.*
- Specify threads-per-inch, spindle speed, and depth and the Control does the rest.

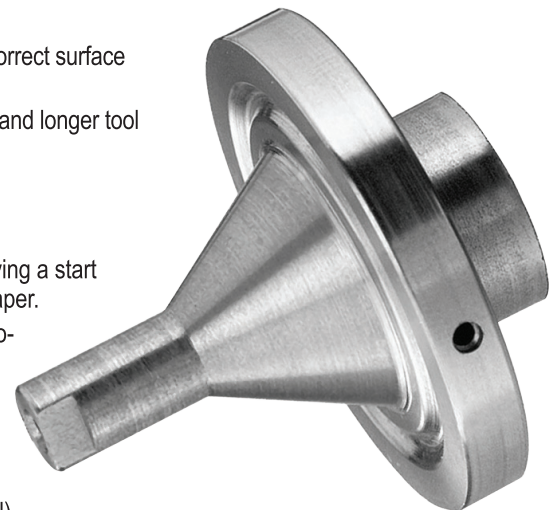

T-400 Options

- Dual Handwheels
- C-Axis
- Rigid Tapping
- MPG Handwheel
- Sealed Keyboard



Retrofit upgrade & OEM CNC Control Systems

Dual Handwheels

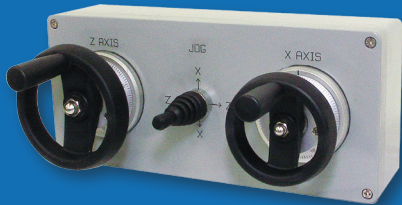

- Electronic wheels for each axis combines manual control with CNC machining for easy part setups.
- Center mounted joystick allows for easy jogging of both X and Z axes in both directions
- Can be mounted anywhere on the lathe with the provided sealed mounting box



CNC Retrofits for:

- Flat Beds
- Slant Beds
- Turning Centers
- VTL's

Popular Retrofits:

Fanuc, Prototrak, Mori Seiki, Ikegai, Bullard, Pratt&Whitney, Hardinge, Mazak, LeBlond, Berthiez, Warner Swasey, Cincinnati, Okuma, Daewoo, Star, Hitachi Seiki and many more.

Eliminate expensive repair cost, by replacing old troublesome controls and return good iron back to a profit center with a new CENTROID T400 CNC control. Retrofit and save \$ compared to buying a new machine. No need to move the machine, professional on-site CNC installation and training is available worldwide. Replacement CNC systems are available for almost all makes and models. Added value: easier setup and programming, new time saving features not found on old control, reliable CNC system is Made in USA.

Designed to last, Low operating cost

CENTROID has been designing and manufacturing its own CNC control components for over 30 years.

Made-in-the-USA in house electronics production and quality control allows us to provide the industry's most affordable replacement parts & repair long after the sale.

Year after year, low CENTROID CNC control operating costs increase your bottom line.

CENTROID is a U.S.-owned and operated company with thousands of CNC controls in operation worldwide.

Stay current with updates

- Software updates allow CENTROID users to stay current with the latest CNC technology. CENTROID supports both its CNC hardware and software with affordable parts, service and updates.
- With the USB thumb drive software updates, future CNC features can be added to the control in just minutes.
- Remote support access allows Users and CNC technicians to connect to the control via the internet.
- Familiar Windows 7 operating system allows web cams, skype, remote monitoring, remote access and many other useful windows applications to run on the control.

Certified Worldwide Support

- Worldwide network of factory-trained and certified technicians provide fast and affordable CNC sales, training, service, and support.

Distributor:



CENTROID

159 Gates Road • Howard, PA 16841

Sales: (814) 353-9256 • Fax: (814) 353-9265

www.centroidcnc.com



Applies to standard export models:

- Minimum programmable increment = .001mm
- "Numerical control" units have three axis simultaneous contouring

*optional

Copyright © 2012 CENTROID 9-11-12 rev6